

*Congratulations on your selection of another quality antenna product from E/M Wave.  
 E/M Wave is committed to continually provide the greatest antenna VALUE for your wireless applications.*

**1. Parts (Figure 1):**

Verify all parts are included with the Antenna as shown in Figure 1.

- A. Antenna Whip
- B. e/m-Flex™ Poly Spring Assembly
- C. NMO Base Adapter
- D. O-Ring

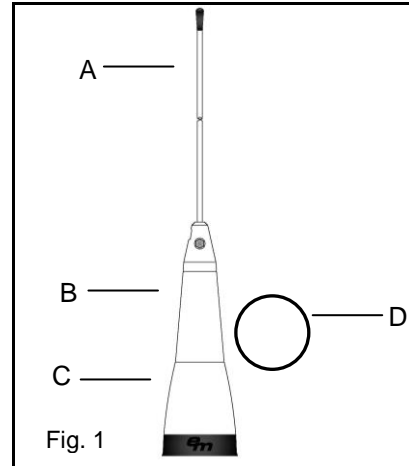

**2. Tools:**

- a. Tool for cutting stainless steel whip
- b. Hex Wrench (3/32")
- c. **Note:** Special tools are not required to install the antenna. The antenna is intended to be installed using a firm hand torque until the sealing O-ring is completely compressed against the installation surface.

**3. Pre-Installation (Figure 2):**

- a. **Optimal VSWR and Bandwidth:** Best performance is achieved when mounted to a non-metallic surface or small metal L-Bracket.
- b. **Mounting Option:** Metallic ground plane surface.
- c. Ensure O-ring is properly seated within O-ring groove as shown in Figure 2.
- d. **Important:** Verify proper operational frequency, as labeled. (Figure 2).
- e. Read and follow all Whip Cutting Instructions supplied for this model.

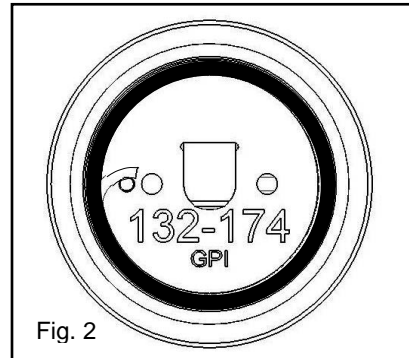

**4. Tuning and Installation (Figure 3):**

- a. Verify contact spring is completely extended. If necessary, adjust by pulling the contact upward.
- b. Thread NMO Base Adapter onto the NMO mount. Tighten by hand until O-Ring is completely seated.
- c. Thread Spring onto NMO Base Adapter. Firmly torque by hand.
- d. Refer to whip cutting instructions. Cut whip length according to desired frequency and either ground plane or no ground plane installation.
- e. Verify VSWR. Apply firm torque to whip adapter set screws (2 ea.).

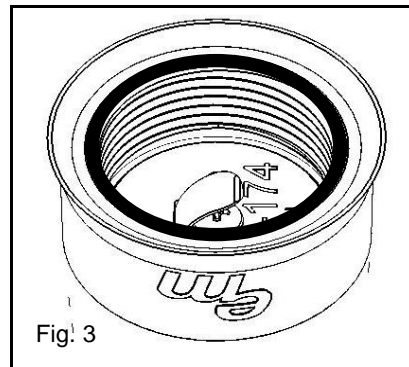

**WHIP CUTTING INSTRUCTIONS FOR TUNING EMFLX-M10004-GPI**  
**“Ground Plane” and “No Ground Plane” Installations**

**PLEASE CAREFULLY READ ALL INSTRUCTIONS BEFORE CUTTING THE WHIP.**

CENTER FREQUENCY (± BANDWIDTH)	TUNED WHIP LENGTH "W" <u>NO</u> GROUND PLANE		TUNED WHIP LENGTH "W" GROUND PLANE	
	(MHz)	(inches)	(mm)	(inches)
135 (± 7)	47-3/4	1213	41-3/4	1060
140 (± 7.5)	44-1/16	1120	39-3/8	1000
145 (± 7.5)	41-5/16	1050	37-7/8	963
150 (± 7.5)	38-9/16	980	35-5/8	905
155 (± 8)	36-1/2	928	34-1/4	870
160 (± 8)	34-1/2	876	32-1/2	826
165 (± 8)	32-3/4	833	30-3/4	781
170 (± 9)	31-1/16	789	29-5/16	745
174 (± 9)	30-1/16	763	28-1/4	714

Table 1

**1. IMPORTANT! Before Cutting.**

**OPTIMAL PERFORMANCE:** This antenna is specifically designed for precision VSWR performance at the desired center frequency. Tuning the whip per Table 1 will provide optimal VSWR match across the bandwidth specified. VSWR bandwidth may vary depending on the actual installation surface material, location, bracket type and size.

**CUTTING NOTE:** The whip can be cut using a grinding wheel or shearing tool designed for this purpose. Due to a large variation of installations without a conductive ground plane surface, it is strongly recommended to cut the whip slightly longer than the specified dimensions in Table 1. If necessary, continue to trim for best VSWR match. Always verify actual VSWR or Return Loss performance after cutting and installation.

**TUNED LENGTH "W"** is determined by measuring the distance between the top of the whip adapter and the top of the whip. **NOTE: The actual cut length will be approximately 1" (25mm) longer than TUNED WHIP LENGTH "W".**

- 2. Choose the column in Table 1 for “Ground Plane” or “No Ground Plane” installation.
- 3. Identify the desired center frequency of operation.
- 4. Imperial and Metric units are given for convenience. Cut the whip as required to establish the specified **TUNED WHIP LENGTH "W"** as shown in Figure 4.
- 5. Verify VSWR. Secure set screws (2 ea.).

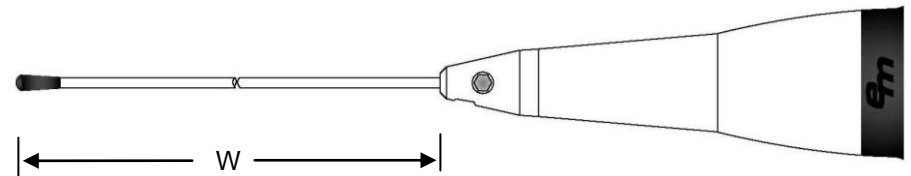

[Note: Add 1" (25mm) to Tuned Length "W" when cutting whip.] Fig. 4